

## Features:

- ☞ Up to 1.25Gb/s Data Links
- ☞ Hot-Pluggable
- ☞ Single LC connector
- ☞ Up to 20 km on 9/125µm SMF
- ☞ 1310nm FP and 1550nm DFB laser transmitter
- ☞ 1550nm and 1310nm PIN photo-detector
- ☞ Single +3.3V Power Supply
- ☞ Monitoring Interface Compliant with SFF-8472
- ☞ Operating temperature range: -40°C to 85°C/-5°C to 85°C/-0°C to 70°C
- ☞ RoHS compliant and Lead Free

## Applications:

- ☞ 1000Base-LX Ethernet
- ☞ Metro/Access Networks
- ☞ 1×Fibre Channel
- ☞ Other Optical Links

## Specification:

### ● Electrical and Optical Characteristics: (Condition: $T_a=T_{OP}$ )

Parameter	Symbol	Min.	Typical	Max.	Unit
Transmitter Differential Input Voltage	+/-TX_DAT	200		2400	mV p-p
Supply Current	I <sub>CC</sub>		150	300	mA
Tx_Disable Input Voltage – Low	V <sub>IL</sub>	0		0.8	V
Tx_Disable Input Voltage – High	V <sub>IH</sub>	2.0		V <sub>CC</sub>	V
Tx_Fault Output Voltage – Low	V <sub>OL</sub>	0		0.8	V
Tx_Fault Output Voltage – High	V <sub>OH</sub>	2.0		V <sub>CC</sub>	V
Receiver Differential Output Voltage	+/-RX_DAT	600		1400	mV p-p
Rx_LOS Output Voltage- Low	V <sub>OL</sub>	0		0.8	V
Rx_LOS Output Voltage- High	V <sub>OH</sub>	2.0		V <sub>CC</sub>	V

### ● Characteristics of Transmitter

Transmitter :						
Parameter		Symbol	Min.	Typical	Max.	Unit
Data Rate		B	-	1250	-	Mb/s
Centre Wavelength	TM-4663S-243x	$\lambda_c$	1300	1310	1320	nm
	TM-466BF-243x		1530	1550	1570	

Output Spectral Width(1310nm)	$\Delta\lambda$ (RMS)	-	-	4	nm	
Output Spectral Width(1550nm)	$\Delta\lambda$	-	-	1	nm	
Side-mode Suppression Ratio (1550nm)	SMSR	30	-	-	dB	
Average Output Power	$P_o$	-9	-	-3	dBm	
Extinction Ratio	EXT	9	-	-	dB	
Data Input Voltage-High	$V_{IHS}$	$V_{cc}-1.16$	-	$V_{cc}-0.89$	V	
Data Input Voltage -Low	$V_{ILS}$	$V_{cc}-1.82$	-	$V_{cc}-1.48$	V	
Supply Current	$I_{CC}$	-	80	150	mA	
Output Optical Eye	Compliant with IEEE802.3Z					
<b>Receiver :</b>						
Parameter		Symbol	Min.	Typical	Max.	Unit
Operating Wavelength	TM-4663S-243x	$\lambda_c$	1520	1550	1580	nm
	TM-466BF-243x		1280	1310	1350	
Receive Sensitivity		$P_{min}$	-	-	-24	dBm
Hysteresis		-	-	3.0	-	dBm
Maximum Input Power		$P_{MAX}$	-3	-	-	dBm
Signal Detection-Deserted		$SD_{LOW}$	-45	-	-	dBm
Signal Detection-Asserted		$SD_{HIGH}$	-	-	-36	dBm
Output High Voltage		$V_{OH}$	$V_{cc}-1.03$	-	$V_{cc}-0.89$	V
Output Low Voltage		$V_{OL}$	$V_{cc}-1.82$	-	$V_{cc}-1.63$	V
Supply Current		$I_{CC}$	-	80	150	mA

● **Absolute Maximum Ratings: ( $T_C=25^\circ C$ )**

Parameter	Symbol	Min.	Max.	Unit
Storage Temperature	$T_{ST}$	-40	+85	$^\circ C$
Operating Temperature	$T_{IP}$	0(-40)	+70(+85)	$^\circ C$
Input Voltage	$T_{CC}$	0	+5	V

● **Recommended Operating Environment:**

Parameter	Symbol	Min.	Typical	Max.	Unit
Supply Voltage	$V_{CC}$	+3.0	+3.3	+3.6	V

Operating Temperature	T <sub>OP</sub>	0(-40)	-	+70(+85)	°C
-----------------------	-----------------	--------	---	----------	----

● **Timing Characteristics:**

Parameter	Symbol	Min.	Typical	Max.	Unit
TX_DISABLE Assert Time	t <sub>off</sub>		3	10	usec
TX_DISABLE Negate Time	t <sub>on</sub>		0.5	1	msec
Time to Initialize Include Reset of TX_FAULT	t <sub>int</sub>		30	300	msec
TX_FAULT from Fault to Assertion	t <sub>fault</sub>		20	100	usec
TX_DISBEL Time to Start Reset	t <sub>reset</sub>	10			usec
Receiver Loss of Signal Assert Time (Off to On)	T <sub>A,RX_LOS</sub>			100	usec
Receiver Loss of Signal Assert Time (On to Off)	T <sub>d,RX_LOS</sub>			100	usec

● **Serial ID Memory Contents:**

Data Address	Length (Byte)	Name of Length	Description and Contents
Base ID Fields			
0	1	Identifier	Type of Serial transceiver (03h=SFP)
1	1	Reserved	Extended identifier of type serial transceiver (04h)
2	1	Connector	Code of optical connector type (07=LC)
3-10	8	Transceiver	Gigabit Ethernet 1000Base-SX & Fiber Channel
11	1	Encoding	8B10B (01h)
12	1	BR,Nominal	Nominal baud rate, unit of 100Mbps
13-14	2	Reserved	(0000h)
15	1	Length(9um)	Link length supported for 9/125um fiber, units of 100m
16	1	Length(50um)	Link length supported for 50/125um fiber, units of 10m
17	1	Length(62.5um)	Link length supported for 62.5/125um fiber, units of 10m
18	1	Length(Copper)	Link length supported for copper, units of meters
19	1	Reserved	
20-35	16	Vendor Name	SFP vendor name
36	1	Reserved	
37-39	3	Vendor OUI	SFP transceiver vendor OUI ID
40-55	16	Vendor PN	Part Number
56-59	4	Vendor rev	Revision level for part number
60-62	3	Reserved	
63	1	CCID	Least significant byte of sum of data in address 0-62
Extended ID Fields			
64-65	2	Option	Indicates which optical SFP signals are implemented (001Ah = LOS, TX_FAULT, TX_DISABLE all supported)
66	1	BR, max	Upper bit rate margin, units of %

67	1	BR, min	Lower bit rate margin, units of %
68-83	16	Vendor SN	Serial number (ASCII)
84-91	8	Date code	Manufacturing date code
92-94	3	Reserved	
95	1	CCEX	Check code for the extended ID Fields (addresses 64 to 94)
Vendor Specific ID Fields			
96-127	32	Readable	specific date, read only

### ● Digital Diagnostic Monitoring Functions

2-wire serial bus address 1010001X (A2h) is used to access measurement of transceiver temperature, internally measured supply voltage, TX bias current, TX optical output power and RX optical input power which are shown in table 1. Each diagnostic parameter has a corresponding high alarm, low alarm, high warning and low warning threshold which are shown in table 2.

Table 1. Diagnostic Parameters

Diagnostic Parameter	Range		LSB	Accuracy	Address	Note
	Min	Max				
Transceiver Temperature (Temp)	-50[°C]	+80[°C]	1/256[°C]	±3[°C]	96-97	A 16bit signed two's complement value
Supply Voltage (Voltage)	+3.0[V]	+3.6[V]	100[ $\mu$ V]	±3[%]	98-99	A 16bit unsigned integer
TX Bias Current (Bias)	3[mA]	95[mA]	2.0[ $\mu$ A]	±10[%]	100-101	A 16bit unsigned integer
TX Optical Output Power (TX Power)	-10[dBm]	-4[dBm]	0.1[ $\mu$ W]	±3 [dB]	102-103	A 16bit unsigned integer
RX Optical Input Power (RX Power)	-24[dBm]	+0[dBm]	0.1[ $\mu$ W]	±3 [dB]	104-105	A 16bit unsigned integer

Table 2. Alarm and Warning Thresholds

Parameter	Warning		Alarm		Unit
	Low	High	Low	High	
Transceiver Temperature (Temp)	-40	+80	-20	+90	°C
Supply Voltage (Voltage)	+3.13	+3.47	+3.0	+3.6	V
TX Bias Current (Bias)	5	85	3	95	mA
TX Optical Output Power (TX Power)	-9	-2	-10	-3	dBm

RX Optical Input Power (RX Power)	-24.5	+1	-25.5	+2	dBm
--------------------------------------	-------	----	-------	----	-----

**Block Diagram of Transceiver:**

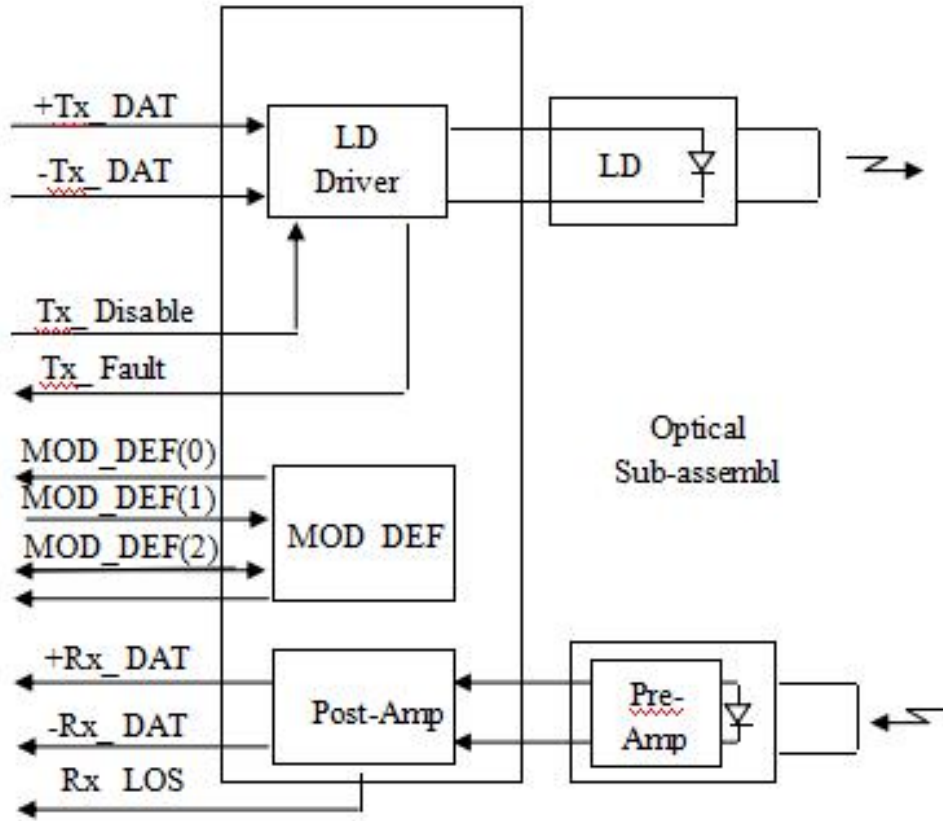

**Pin Assignment:**

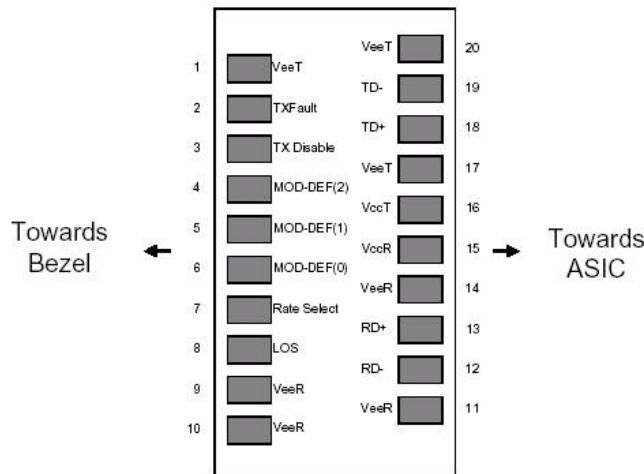

### Pin out of Connector Block on Host Board

#### Pin Description:

Pin	Symbol	Name/Description	Ref.
1	V <sub>EET</sub>	Transmitter Ground (Common with Receiver Ground)	1
2	T <sub>FAULT</sub>	Transmitter Fault. Not supported.	
3	T <sub>DIS</sub>	Transmitter Disable. Laser output disabled on high or open.	2
4	MOD_DEF(2)	Module Definition 2. Data line for Serial ID.	3
5	MOD_DEF(1)	Module Definition 1. Clock line for Serial ID.	3
6	MOD_DEF(0)	Module Definition 0. Grounded within the module.	3
7	Rate Select	No connection required	
8	LOS	Loss of Signal indication. Logic 0 indicates normal operation.	4
9	V <sub>EER</sub>	Receiver Ground (Common with Transmitter Ground)	1
10	V <sub>EER</sub>	Receiver Ground (Common with Transmitter Ground)	1
11	V <sub>EER</sub>	Receiver Ground (Common with Transmitter Ground)	1
12	RD-	Receiver Inverted DATA out. AC Coupled	
13	RD+	Receiver Non-inverted DATA out. AC Coupled	
14	V <sub>EER</sub>	Receiver Ground (Common with Transmitter Ground)	1
15	V <sub>CCR</sub>	Receiver Power Supply	
16	V <sub>CCT</sub>	Transmitter Power Supply	
17	V <sub>EET</sub>	Transmitter Ground (Common with Receiver Ground)	1
18	TD+	Transmitter Non-Inverted DATA in. AC Coupled.	
19	TD-	Transmitter Inverted DATA in. AC Coupled.	
20	V <sub>EET</sub>	Transmitter Ground (Common with Receiver Ground)	1

#### Notes:

1. Circuit ground is internally isolated from chassis ground.
2. Laser output disabled on TDIS >2.0V or open, enabled on TDIS <0.8V.
3. Should be pulled up with 4.7k – 10kohms on host board to a voltage between 2.0V and 3.6V.  
MOD\_DEF(0) pulls line low to indicate module is plugged in.
4. LOS is open collector output. Should be pulled up with 4.7k – 10kohms on host board to a voltage between 2.0V and 3.6V. Logic 0 indicates normal operation; logic 1 indicates loss of signal.

#### Ordering information:

Part Number	Package	Rate	Fiber type	Distance	Wavelength (nm)	Temperature (°C)
TM-4663S-243E	SFP	1.25Gbps	SMF	20km	T1310R1550	0/+70
TM-466BF-243E	SFP	1.25Gbps	SMF	20km	T1550R1310	0/+70
TM-4663S-243I	SFP	1.25Gbps	SMF	20km	T1310R1550	-40/+85
TM-466BF-243I	SFP	1.25Gbps	SMF	20km	T1550R1310	-40/+85

**Mechanical Dimensions:**

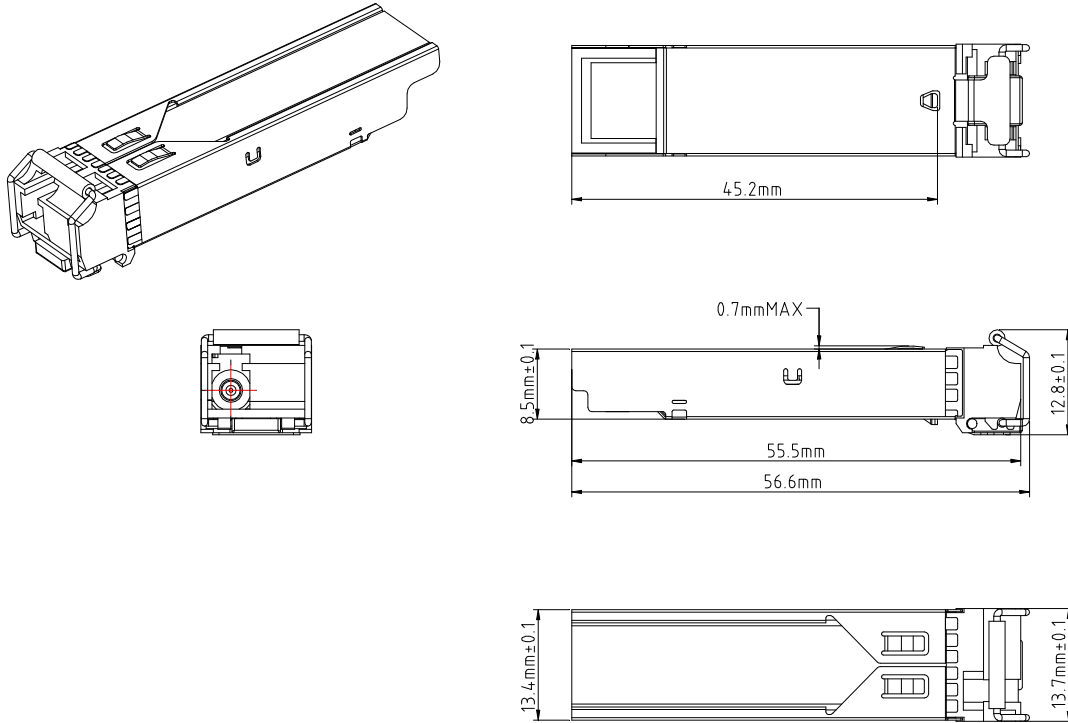

**Recommended Circuit:**

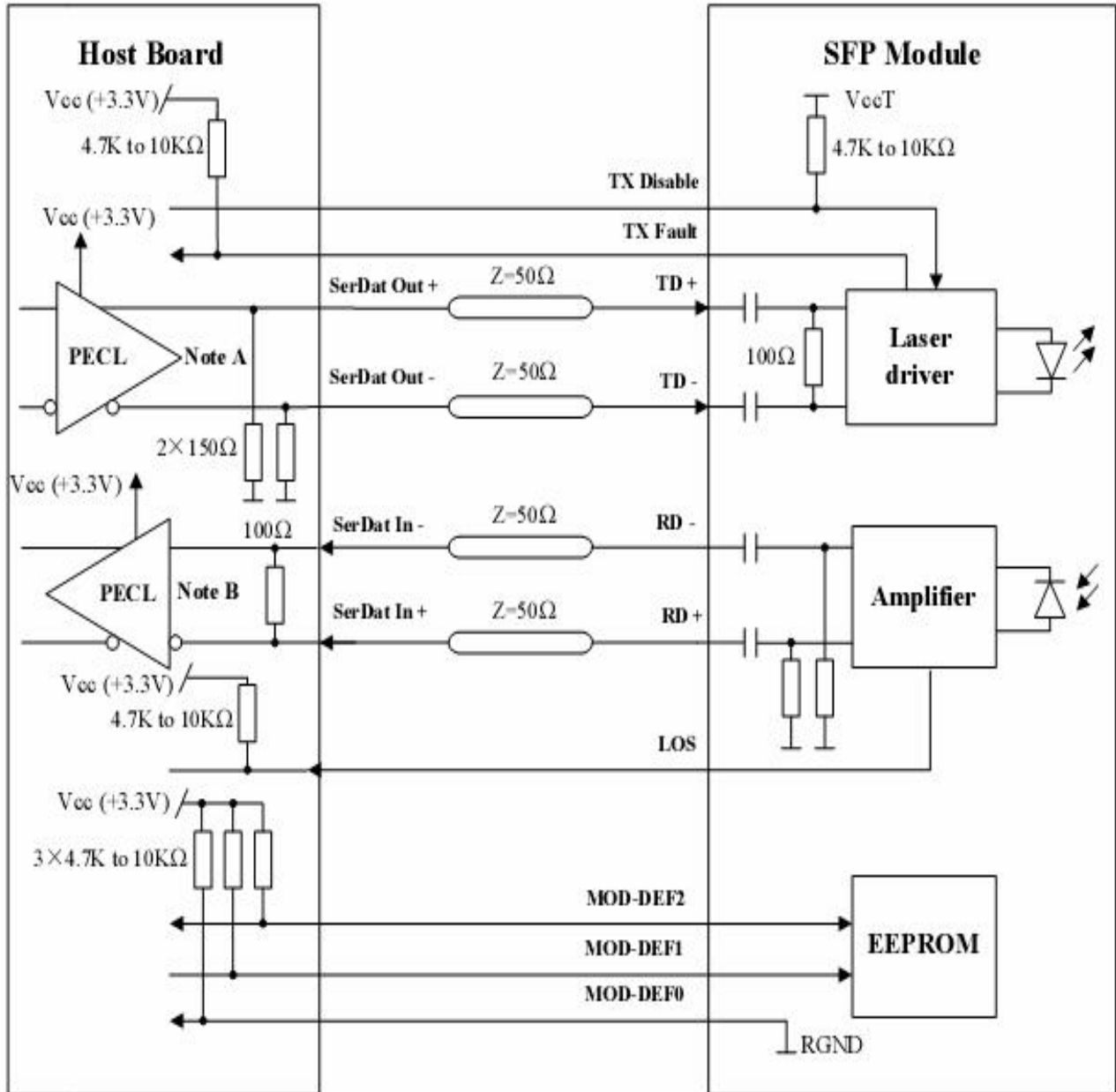

Note A: Circuit assumes open emitter output

Note B: Circuit assumes high impedance internal bias @Vcc-1.3V